

Solar Pumping Inverter User Manual



Figure 1 ADA solar pumping inverter

Designed & Manufactured by
Shenzhen ADA Power Electronics Co., Ltd

Safety Instruction

To ensure safe operation of solar pumping inverter, it must choose the right way of transportation, installation, operation and maintenance. Please be aware of the safety notices before operation:



Warning: Misuse will result in fire, serious injury to person or even death.



Caution: misuse will cause low or middle-grade injury to person or equipment damage.



Prompt: Point out some useful information

First Inspection



Caution

If inverter is damaged or missing parts, no installation allowed in case of any accidents.

Installation



Caution

- 1.It must be installed vertically for good convection cooling effect .
- 2.Keep under the condition of good ventilation opening or ventilating device. Never exposes directly to the sunlight.

Connection



Caution

- 1.All wire cable connection must be under the instruction of correct wiring diagram .
- 2.Handling by qualified electrical professionals, all wire cable should be wrapped with electrical tape for safety.

Storage



Caution

Placed in dry, dust-free, no corrosive gas, liquid.

Temperature of the storage location must be at the -20 to +70 .

Relative Humidity of the storage location must be between 5% to 90% range, and no condensation.

Chapter 1 System Introduction

1.1 Brief Introduction

A complete solar pumping system consist of solar array, pump and solar pumping inverter. SPI series solar pumping inverter can convert the DC power from solar PV array to AC power to run pump motors.

Solar array, an aggregation of many solar modules connected in series and parallel, absorbs sunlight radiation and converts it into electrical energy, providing dynamical water for the whole system.

Inverter controls the system operation and adjust the output frequency in real-time according to the variation of sunlight intensity to realize the maximum power point tracking (MPPT).

Pump, drive by 3-phase AC motor, can draw water from the deep wells or rivers and lakes to pour into the storage tank or reservoir, or directly connect to the irrigation system, fountain system, etc.

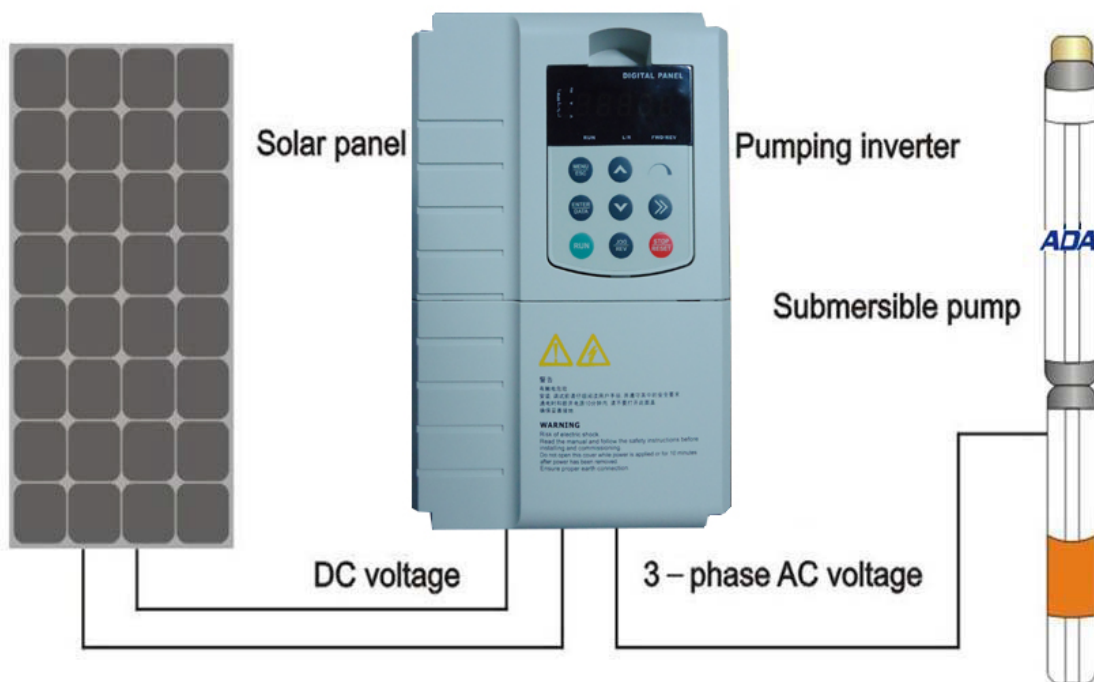

Figure 2 Structure of solar pumping system

Chapter 2 Solar Pumping Inverter

2.1 Inverter Specification

Model Description

Model numbers on name plate consist of numbers, symbols, and letters, to express its respective series, suitable power type, power level and other information.

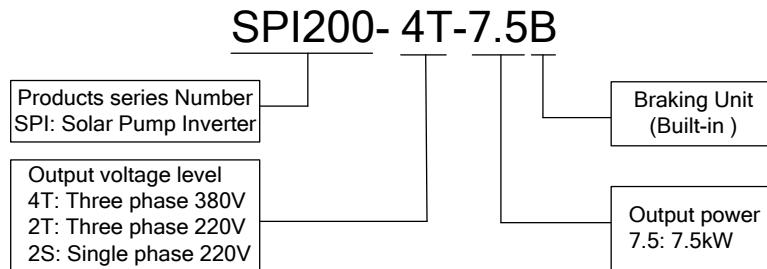

2.2 Inverter Features

- Apply to all kinds of single phase or 3 phase AC induction motor .
- With Infineon IGBT .Maximum power point tracking (MPPT) algorithm for dynamic VI, fast response speed,
- Good stability, the efficiency of MPPT 99.99%;
- Both AC and DC input, but can not use DC and AC at the same time.
- For single phase inverter , MPPT working voltage is 180V~450V ; for three phase inverter , MPPT working voltage is 250V~800V .
- Remote control , support RS323/RS485 protocol.
- Outdoor working environment temperature: -10 ~+40
- Start in the morning and stop in the late afternoon full automatically.
- Full protections : overload , overcurrent, over voltage , undervoltage ,short circuit , dry pumping etc, PV reversed connection protection.

2.3 Parameters :

Solar Pump Inverter						Solar Array	AC Pump
Model	Rated Power(KW)	Max. DC Input Voltage(V)	MPPT Voltage(V)	Rated output Voltage(V)	Output Frequency(Hz)	DC Power(KW)	Rated Power(KW)
SPI100-2S-0.7B	0.75	450	250-400	Single PH 220	0-50/60	0.825	0.75
SPI100-2S-1.5B	1.5	450	250-400	Single PH 220	0-50/60	2.25	1.5
SPI100-2S-2.2B	2.2	450	250-400	Single PH 220	0-50/60	3.3	2.2
SPI100-2S-4.0B	4	450	250-400	Single PH 220	0-50/60	6.0	4.0
SPI100-2T-0.7B	0.75	450	250-400	3PH220	0-50/60	0.825	0.75
SPI100-2T-1.5B	1.5	450	250-400	3PH220	0-50/60	2.25	1.5
SPI100-2T-2.2B	2.2	450	250-400	3PH220	0-50/60	3.3	2.2
SPI100-2T-4.0B	4	450	250-400	3PH220	0-50/60	6.0	4.0
SPI100-2T-5.5B	5.5	450	250-400	3PH220	0-50/60	8.25	5.5
SPI200-4T-0.7B	0.75	800	450-800	3PH380	0-50/60	0.825	0.75
SPI200-4T-1.5B	1.5	800	450-800	3PH380	0-50/60	2.25	1.5
SPI200-4T-2.2B	2.2	800	450-800	3PH380	0-50/60	3.3	2.2
SPI200-4T-4.0B	4.0	800	450-800	3PH380	0-50/60	6	4.0
SPI200-4T-5.5B	5.5	800	450-800	3PH380	0-50/60	8.25	5.5
SPI200-4T-7.5B	7.5	800	450-800	3PH380	0-50/60	11.25	7.5
SPI200-4T-11B	11	800	450-800	3PH380	0-50/60	16.5	11
SPI200-4T-15B	15	800	450-800	3PH380	0-50/60	20	15
SPI200-4T-18.5B	18.5	800	450-800	3PH380	0-50/60	24	18.5
SPI200-4T-22B	22	800	450-800	3PH380	0-50/60	29	22
SPI200-4T-30B	30	800	450-800	3PH380	0-50/60	39	30
SPI200-4T-37B	37	800	450-800	3PH380	0-50/60	48	37
SPI200-4T-45B	45	800	450-800	3PH380	0-50/60	54	45
SPI200-4T-55B	55	800	450-800	3PH380	0-50/60	66	55
SPI200-4T-75B	75	800	450-800	3PH380	0-50/60	90	75
SPI200-4T-90B	90	800	450-800	3PH380	0-50/60	108	90
SPI200-4T-110B	110	800	450-800	3PH380	0-50/60	132	110

2.4 Technical Parameter Table

2.4.1 Single phase inverter (SPI100-2S-0.7B~4.0B, SPI100-2T-0.7B~5.5B)

Input specification	
PV Input	
Maximum Input DC Voltage	450VDC
Recommended MPPT Voltage Range	250~400VDC
Recommended Input Operation Voltage	310VDC (Vmpp)
Grid or backup generator input	
Input voltage	1PH & 3PH 220V(-15%~30%)
Output specification	
Rated output voltage	1PH & 3PH 220V
Output frequency	0~600.00Hz (default: 0~60.00Hz)
Protection	
Built-in Protection	Lighting Protection, over-current, overvoltage, output phase-lose, under-load, under-voltage, short circuit, overheating, water pump run dry etc.

2.4.2 Three Phase inverter (SPI200-4T-0.7B~110B)

Input specification	
PV Input	
Maximum Input DC Voltage	800VDC
Recommended MPPT Voltage Range	450~600VDC
Recommended Input Operation Voltage	540VDC (Vmpp)
Grid or backup generator input	
Input Voltage	Three phase 380V(-15%~30%)
Output specification	
Rated output voltage	3PH 380V
Output frequency	0~600.00Hz (Default 0~60.00Hz)
Protection	
Built-in Protection	Lighting Protection, over-current, overvoltage, output phase-lose, under-load, under-voltage, short circuit, overheating, water pump run dry etc.
General Parameters	
Application Site	No direct sunshine, no dust, corrosive gas, combustible gas, oil mist, steam, dripping or salinity etc.

Altitude	0~2000 m Derated use above 1000m,per 100m, the rated output current decrease 1%.
Environment Temperature	-10℃~40℃ (Environment Temperature be 40℃~50℃, please keep derated use.)
Humidity	5~95%,non-condensation
Vibration	less than 5.9 m/s ² (0.6g)
Storage Temperature	-20℃~+70℃
Efficiency	Rated Power Run≥93%
Installation	Wall or rail mounting
Cooling	Forced Air Cooling

2.5 Inverter Introduction



2.5.1 Brief Instruction



Figure 3 Inverter keypad

2.5.2 Operation panel button and potentiometer function

	MENU/ESC	Enter or exit Level I menu
	ENTER/DATA	Enter the menu interfaces level by level, and confirm the parameter setting
	UP	Increase data or function code
	DOWN	Decrease date or function code
	SHIFT	Select the displayed parameters in turn in the stop or running state, and select the digit to be modified when modifying parameters

	RUN	Start the inverter in the keypad control mode
	STOP/RESET	Stop the inverter when it is in the running state and perform the reset operation when it is in the fault state
	JOG/REV	Perform function switchover (such as jog run and quick switchover of command source or direction)

2.5.3 Main Circuit Terminals

2.5.3.1 Schematic Diagram for Connection of Main Circuit Terminals

① Connection diagram of main circuit for the inverter of 220v

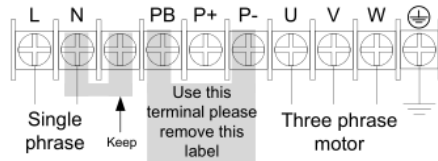

Figure 4 Terminals Connection diagram of main circuit for the inverter of 220v

② Connection diagram of main circuit for the inverter of 380v below 2.2KW

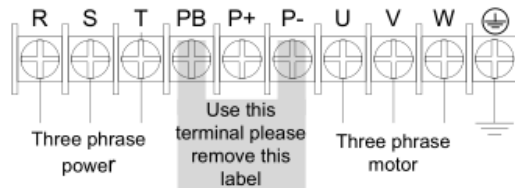

Figure 5 Connection diagram of main circuit for the inverter of 380V below 2.2KW

③ 3.7kW~15kW Connection diagram of main circuit for the inverter of 380v 3.7KW-15KW

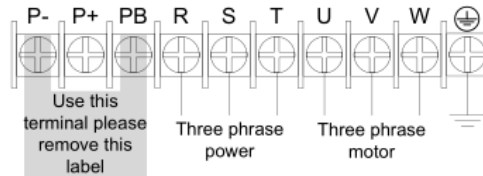

Figure 6 Connection diagram of main circuit for the inverter of 380V 3.7kw-15kw

④ Connection diagram of main circuit for the inverter of 380v up 18.5kw

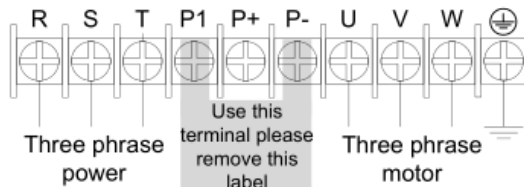





Figure 7 Connection diagram of main circuit for the inverter of 380V over 18.5kw

2.5.3.2 Instructions of main circuit terminals of inverter:

Terminals	Function Instruction
L,N	single-phase 220V input terminal, external connection of grid single phase 220V AC power
R,S,T	input terminal of AC 3-phase power, external connection of grid 3phase AC power
U,V,W	output terminal of 3phase power, external connection of AC 3phase motor
P+,P-	Negative and positive terminals of DC power, external connection of brake unit terminal
P+,PB	External connecting of brake resistor terminal
P1,P+	External connection of DC electric reactor terminal
	Earth terminal

 DANGER
<ul style="list-style-type: none"> ● the voltage class of VD300A series inverter 3phase power has 2 class: 220V, 380V, before connecting power, please make sure the power class on inverter nameplate is the same with the accessing power. Otherwise do not connect. ● DC bus P+ P-terminal: take note that when power outage there is residual voltage on DC bus P+ P- terminal, need to wait for a while until CHARGE LED off. Otherwise it is danger of electric shock. ●When selecting external brake unit, note the polarity of P= P- cannot be reversely connected, otherwise it can result in damage or even fire. <p>Do not directly connect brake resistor to DC bus, it may result damage or fire.</p>

 WARNING
<ol style="list-style-type: none"> 1) Input power L,N or R, S T: the cable connection at input side of the inverter has no phase sequence requirement. 2) Brake unit cable length should not exceed 10m, twisted pair or double cable parallel wiring should be used. 3)Brake resistor connecting terminal P+ P-: confirm whether the device has built-in brake unit, its brake resistor connecting terminal is effect. The brake resistor selection table 2-4 recommending value and the wiring distance should less than 5M. Other it can damage inverter. 4)External DC electric reactor connecting terminal P1 P+: for external DC reactor to 18.5Kw and above power inverter, get rid off the connector between P1 P+ terminal during installation, reactor is installed between the 2 terminal. 5)Inverter output side U V W: the output side cannot connect capacitor or surge absorber, otherwise it will affect inverter in self-protection frequently or damage. 6)In case the motor cable is too long, it may generate electrical resonance easily due to the impact of distributed capacitance, thus damaging the motor insulation or generating higher leakage current to invoke over current protection of the inverter. When the length of motor cables longer than 100 meters, it needs to install a AC output reactor. 7)Earth terminal PE: This terminal shall be earthed reliably, with resistance of earth cable of less than 10Ω. Otherwise, it may cause fault or damage the inverter. Do not share the earth terminal with zero line N terminal, otherwise it will result equipment abnormal running or damage.

2.5.4 Control Circuit terminal

① Control terminals and Functional

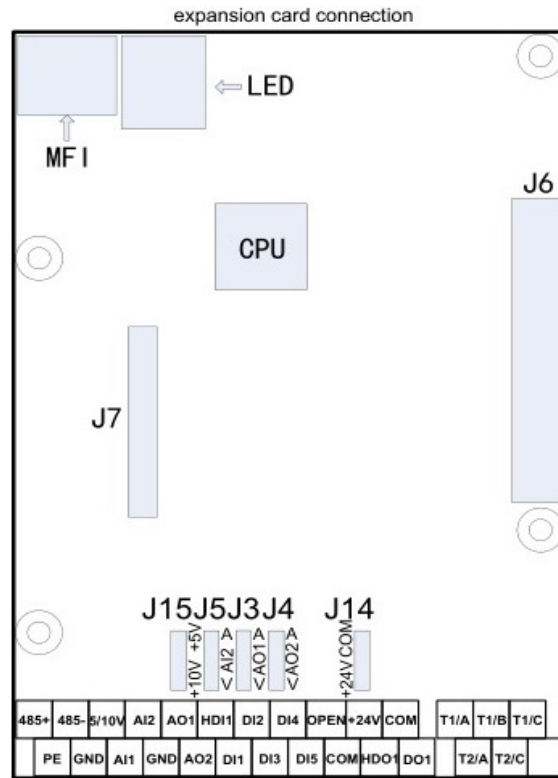

Figure 4 Diagram of main control board and function extension card connection

② Function description of control circuit

Type	Terminal sign	Terminal name	function
Power supply	5V/10V-GND	External 5V/10V power supply	1. provide +5V/10V power supply for external-units, the maximum output current is 20mA.J15 jumper on main control board to select 5V or 10V power output, default is 10V. 2.It is generally used as the operating power supply for the external potentiometer. The potentiometer resistance range is 1kΩ~10KΩ
	+24V-COM	24V power supply	1.Provide +24V power supply for external units. It is generally used as the operating power supply for digital input/output terminals and the external sensor. The maximum output current is 200mA.
	OPEN	External power input terminal	1. Connect to 24V by default, J14 jumper on main control board to select +24V or COM connection. 2. When external power is used to drive DI1~DI5, HDI1, OPEN needs to connect to the external power supply and disconnect J14(disconnecting with +24V/COM).
Communication	485+-485-	RS-485 terminals	Standard RS-485 communication terminal, should use twisted pair cable
Analog input	AI1-GND	Analog input terminal 1	1.Input Voltage range :DC 0V to 10V 2. input resistance : 22kΩ
	AI2-GND	Analog input terminal 2	1.Input range :DC 0V to 10V or 0/4mA~20mA, can be selected by J5 jumper on main control board. 2. input resistance: under voltage input-22 kΩ , Under current input-500Ω .

Digital input	DI1-COM	Digital input 1	1. Optical coupling isolation, compatible with dual polarity input, internal resistance 3.3k Ω ; 2. Multi-function digital input, through P05.01-P05.05 to set function. 3. The inverter default +24v power supply built-in, COM is common terminal. 4. when using external power, JP14 should be suspended, external +24V connect to OPEN, COM is common terminal(external voltage range +24V \pm 10%. 5. internal resistance 1.65 Kw.
	DI2-COM	Digital input 2	
	DI3-COM	Digital input 3	
	DI4-COM	Digital input 4	
	DI5-COM	Digital input 5	
	HDI1-COM	Rapid pulse input terminal	1、 when used as general digit input, it is the same function as DI1 to DI5; can combine with OPEN as bipolar rapid pulse input terminal. Max input frequency is 100kHz. 3、 When use external power, input voltage range +24V \pm 10%; 4、 The internal impedance 1.65 k Ω
Analog output	AO1-GND	Analog output terminal 1	0V~10V voltage and 0/4mA~20mA current output
	AO2-GND	Analog output terminal 2	0V~10V voltage 0/4mA~20mA current output
Digital output	DO1-COM	Digital output 1	1.Optical coupling isolation, dual polarity open collector output 2.Output voltage range: 5V~24V 3.Output current range:2mA~50mA.
	HDO1-COM	Rapid pulse input terminal	1.when used as general digital output, same function as DO1. 2.pull-up voltage range:5V-24V(pull-up impedance range: 0.48 k Ω ~10k Ω). 3.output current range: 2mA~50mA
Relay output	T1/A-T1/B	Relay T1 normally closed terminal	Contact driving capacity: AC250V, 3A,DC 30V, 1A
	T1/A-T1/C	Relay T1 normally open terminal	
	T2/A-T2/C	Relay T2 normally open terminal	
ground	PE	Shield cable ground terminal	1.control cable shield grounding, when the interference is big on site or control cable is too long, the PE should be well grounded to reduce EMC affect. 2.PE is not allowed to connect with power N line, otherwise it can damage inverter

③Jumper switch function description

Jumper Code	Jumper wire	Function
J3	A terminal	When jump cap plug connect to A, AO1 terminal select DC0/4mA-20mA current output
	V terminal	When jump cap plug connect to V, AO1 terminal select DC0V-10V voltage output
J4	A terminal	When jump cap plug connect to A, AO1 terminal select DC0/4mA-20mA current output
	V terminal	When jump cap plug connect to V, AO1 terminal select DC0V-10V voltage output
J5	A terminal	When jump cap plug connect to A, AI2 terminal select DC0/4mA-20mA current output
	V terminal	When jump cap plug connect to V, AI2 terminal select DC0V-10V voltage output

J14	24V terminal	When jump cap plug connect to 24V, OPEN terminal connect with +24V, and HDI1, DI1~DI5 with COM short circuit input effective.
	COM terminal	When jump cap plug connect to 24V, OPEN terminal connect with COM, and HDI1, DI1~DI5 with +24V short circuit input effective.
J15	+5V terminal	When jump cap plug connect to +5V, terminal +5V/10V-GND on main board provide power supply +5V
	+10V terminal	When jump cap plug connect to +10V, terminal +5V/10V-GND on main board provide power supply +10V

④ Jack connection function description

Jack Code	Function	Description
J6	Control board-power board	J6 is connection port of main control board and power board, power board supply power to main control board and is electric signal gateway between the 2 parts
J7	Control board-extension card	J7 is connection port of extension card and main control board, main control board supply power to extension card and is electric signal gateway between the 2 parts
LED	Control board-LED panel	This plug is connection port of main control board and LED panel, main control board supply power to LED panel and is electric signal gateway between the 2 parts
MFI	Control board-MFI interface	This plug is connection port of main control board and MFI port, main control board supply power to MFI port and is electric signal gateway between the 2 parts

2.5.5 Tank water full and Well water dry protection:

Tips:

- 1 use the signal wire connect some screw or conductor to put the sensor inside the well or tank;
- 2 use the water as conductor to connect A, B or disconnect A, B to control the pump inverter ;

A, Tank water full protection

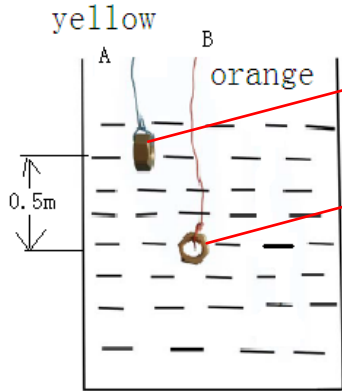

Put the yellow ring where you want to stop the pump

Put the orange B about 0.5 meter lower than yellow A

Reminder:

- 1, only two ring connected by water, and that can stop the pump; when disconnect in air or only one in water, pump continue its working.
- 2, the distance 0.5meter means not too close that stop the pump without water full, or not too far away that can't connect each other even both of them inside water.
- 3, Yellow A and Orange B can exchange the position.

B, Well water dry protection

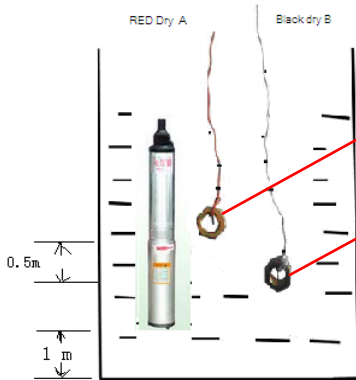

Put the Red A above the pump motor

Put Black B about 0.5 meter lower than Red A

Reminder:

- 1, only two ring disconnected from water, and that can stop the pump; when connect inside the water, pump continue its working.
- 2, the distance 0.5meter means not too close that can't stop the pump when water dry, or not too far away that pump can't start since always disconnected .
- 3, Red A and Black B can exchange the position.



Important remark:

For water dry protection, after the sensor connected ready, we need set: P11.33 = 1.

For water full protection, no need parameter setting.

For the Screw or conductor, we'd better use Anti-oxidant material. otherwise, we need to change a new one in case of rusty or corrosion after few months.

Chapter 3 Function Parameters

3.1 The Basic Function Parameters

The symbols in the function code table are described as follows:

"○" means the value of this parameter can be modified in stop and running status of drive;

"◎" means the value of this parameter cannot be modified when drive is running;

"●" means this parameter is a measured value that cannot be modified;

Default: The value when restored to factory default. Neither measured parameter value nor recorded value will be restored.

Setting Range: the scope of setting and display of parameters.

Code	Name	Description	Factory Default	Attribute
P00.01	Command Source Selection of Run/Start	0: Operation Panel (LED off) 1: Terminal Panel (L/R on) 2: Computer Communications (L/R flash)	1	○
P00.14	Acceleration Time 0	0.0s~3600.0s	2.0s	○
P00.15	Deceleration Time 0	0.0s~3600.0s	0.1s	○
P01.05	Stop mode	0: Ramp to stop 1: Coast to stop	1	○
P01.22	Terminal Control When Power-On	0: Terminal Command Enabled 1: Terminal Command Disabled	1	○
P01.23	Restart when Power-off	0: Forbid to Restart 1: Allow to restart	1	○
P01.24	Wait Time of Restart When Power-off	0.0~3600.0s(whenP01.23, 1Mean Enabled)	1.0s	○
P02.00	Motor1 type	0: Asynchronous motor	0	●
P02.01	Motor 1 Rated Power	0.4kW~1000.0kW	Model Set	◎
P02.02	Motor 1 Rated Voltage	0V~1500V	Model Set	◎
P02.03	Motor 1 Rated Current	0.0A~2000.0A	Model Set	◎
P02.04	Motor 1 Rated Frequency	0.00Hz~650.00Hz	Model Set	◎
P02.05	Motor 1 Rated Rotational Speed	0RPM~65535RPM	Model Set	◎

P05.01	Terminal DI1 Function Selection	0: Disabled 1: Forward run 49: PV Inverter Forbid 50: Full-Water 51: Dry -Water	1	⊙
P05.02	Terminal DI2 Function Selection		50	⊙
P05.03	Terminal DI3 Function Selection		51	⊙
P05.04	Terminal DI4 Function Selection		49	⊙
P05.05	Terminal DI5 Function Selection		0	⊙
P05.11	Terminal DI1~DI5 Positive/Negative Logic	0x00~0x1FF	4	⊙
P05.12	DI Terminal Filtering Time	0.000~1.000s	0.010s	○
P06.02	Output Terminal Positive/Negative Logic	0x0~0x1F	0x0	○
P06.03	DO1 Output Function	0: Disabled 16: Weak Light Pre-Warning 17: Full-Water Pre-Warning 18: Reservoir Dry-Water 19: Analog Reservoir Dry Pumping 20: Terminal Reservoir Dry-Water	16	○
P06.04	HDO1 Output Function		0	○
P06.05	Relay T1 Output Function		17	○
P06.06	RelayT2 Output Function		20	○
P08.26	PID Dormancy Wait Time	0.0s~6000.0s	1.0s	○
P11.16	PV Inverter Selection	0: Disabled 1: Enabled	1	○
P11.17	Vmpp Voltage Selection	0: Constant Voltage 1: Max. Power Point Tacking(MPPT)	1	○
P11.18	Vmpp Voltage Keypad Set	0.0~6553.5Vdc	555.0V	○
P11.19	PID Off set Limits	0.0~100.0%(100.0%对应P11.18)	0.0%	⊙
P11.20	PID Max. Output Frequency	0~100.0%	100.0%	○
P11.21	PID Min. Output Frequency	0.0%~100.0%	0.0%	○
P11.22	KP1	0.00~100.00	1.00	○
P11.23	KI1	0.00~100.00	1.00	○
P11.24	KP2	0.00~100.00	4.00	○
P11.25	KI2	0.00~100.00	4.00	○
P11.26	PI Amplitude	0.0~6553.5Vdc	50.0V	○

P11.27	Analog Channel Selection of Reservoir Water Level	0: Disabled 1: AI1 2: AI2 3: AI3	0	○
P11.28	Dry-Water Threshold	0.0~100.0%	25.0%	○
P11.29	Delay Time of Dry-Water	0~10000s	10s	○
P11.30	Wake-up Delay Time of Dry-Water	0~10000s	300s	○
P11.31	Dry Pumping Threshold	0.0~50.0%	0.0%	○
P11.32	Delay Time of Full-Water	0.0~1000.0s	60.0s	○
P11.33	Dry Pumping Function	0: Disabled 1: Enabled	0	○
P11.34	Reset Delay of Full-Water	0.0~1000.0s	300.0s	○
P11.35	Frequency of Weak Light	0~50Hz	5.00Hz	○
P11.36	Delay Time of Weak Light	0.0~3600.0s	100.0s	○
P11.37	Reset Delay of Weak Light	0.0~3600.0s	300.0s	○
P11.38	Reference Voltage of Given Display	0.0~2000.0V	0V	○
P11.39	Min. Voltage of MPPT	0.0~6553.5Vdc	100.0V	○
P11.40	Max. Voltage of MPPT	0.0~6553.5Vdc	800.0V	○
P14.01	Fault Code	0: No Fault A-LS Warning of Weak Light A-LL Warning of Dry-water A-TF Warning of Full -water Er001: Acceleration Overcurrent (Hardware) Er002: Deceleration Overcurrent (Hardware) Er003: Constant-speed Overcurrent (Hardware) Er004: Acceleration Overcurrent Er005: Deceleration Overcurrent Er006: Constant-speed Overcurrent Er007: Acceleration Overvoltage Er008: Deceleration Overvoltage Er009: Constant-speed Overvoltage Er010: Bus Under voltage protection Er011: Motor Overload Er012: Inverter Overload Er013: Input Open-phase Er014: Output Open-phase Er015: Overheat Er016: Over Current Fault Er017: External Input Fault Er018: Communication Fault	0	●

		Er019: Current Inspect Fault Er020: Self-identification Fault Er021: EEPROM Version Incompatible Er022: PID Feedback Over Limit Er023: PID feedback Disconnection on Running Er024: Motor Ground Circuit Fault Er025: -- Er026: -- Er027: Run Time Over Er028: Power-on Time Over Er029: Off Load Er030: -- Er031: -- Er032: -- Er033: -- Er034: Motor Over Heat Er035: -- Er036: Electronic Over Load Er037~Er040: -- Er041: User Defined Fault 1 Er042: User Defined Fault 2 Er043: User Defined Fault 3 Er044: User Defined Fault 4 Er060: User Time Lock Er061: Factory Time Lock		
P14.02	Output Frequency When Fault	0.00~650.00Hz	0.00	•
P14.03	Output Current When Fault	0.0~2000.0A	0.0	•
P14.04	Output Voltage When Fault	0~2000V	0	•
P14.05	Busbar Voltage when Fault	0.0~2000.0V	0.0	•
P14.06	Input Terminal Status When Fault	0x00~0x1FF	0x00	•
P14.07	Output Terminal Status When Fault	0x00~0x1F	0x00	•
P14.08	Inverter Temperature When Fault	-20.0~120.0°C	0.0	•
P14.09	Run Time When Fault	0~65535min	0	•
P14.10	Power-On Time when Fault	0~65535min	0	•
P14.11	Total Run Time when Fault	0~65535h	0	•
P14.12	Total Power-on When Fault	0~65535h	0	•
P28.00	Run Frequency	0.00Hz~300.00	0.00	•

P28.01	Set Frequency	0.00Hz~300.00	0.00	●
P28.02	Slope Set Frequency	0.00Hz~300.00	0.00	●
P28.03	Busbar Voltage	0.0~2000.0V	0.0	●
P28.04	Output Voltage	0~1200V	0	●
P28.05	Output Current	0.0~2000.0A	0.0	●
P29.00	User Password	0~65535	0	○
P29.01	Parameter Initialization	0: No Operation 1: Factory Reset 2: Remove Factory Record 3: Remove Total Run/Power-On Time	0	◎
P29.02	Item Code	0~65535	Factory Set	●
P29.03	Software Version	1.00~10.00	Factory Set	●
P29.04	Inverter Rated Power	0.4~1000.0kW	Factory Set	●
P29.05	Inverter Rated Voltage	220~1140V	Factory Set	●
P29.06	Inverter Rated Current	2.4~2000.0A	Factory Set	●

Chapter 4 Warranty

4.1 Warranty

The warranty of this inverter is 18 months, or we provide 2% spare parts for free. When any fault or damage occurs on the product, within the warranty period, our company will provide free maintenance. After the warranty time, we can provide lifetime paid warranty service.

4.2 Supplementary

In order to enjoy better after-sales service, please pay attention to the following:

Provide below information when inquiry, we will make good configuration for you.		
1	Pump	Power, Voltage, Phase
2	Solar Panel	Each panel power, voc voltage, vmp voltage
Provide below photos and information after installation.		
1	Pump	Photos show pump, pump specification, pump and inverter connection
2	Inverter	Photos show inverter installation environment, inverter connection and switch, LCD screen parameter setting.
3	Solar Panel	Photos show solar panel and inverter connection, solar panel specification, solar panel array and quantity.



Prompt: Warranty only covers the body of the inverter

4.3 Warranty agreement

1 The warranty of this inverter is 18 months, or 2% spare parts for free. When any fault or damage occurs on the product, within the warranty period, our company will provide free maintenance. After the warranty time, we can provide life time paid warranty service.

2 The warranty time starts from the date when the product is leaving the factory, and the machine frame code is the only proof to determine the warranty period.

3 Certain maintenance charge should be considered during warranty period if the fault is caused by the following reason:

- Fault caused by operating against the manual or surpass the standard specification
- Fault caused by self fix and modification without permission.
- Fault caused by poor preservation
- Fault by using the inverter in a normal function
- Machine damage caused by fire, salt corrosion, gas corrosion, earthquake, storm, flood, lightning, abnormal voltage or other force majeure.

4 Please be sure to retain this card and show it to the maintenance service.

User's Information

User Company: _____	Contact person: _____
Address : _____	Phone: _____
Dealer company: _____	Postcode: _____
Model: _____	Serial number: _____
Purchase date: _____	Handling person: _____

Repair Record

Date	Record	Abstract	Technician	Signature